

A person's profile is shown on the left, looking towards a large print of a city skyline at night. The print is mounted on a wall and shows a tall, illuminated building with a vertical light strip, surrounded by other city buildings and a body of water reflecting the lights. The scene is bathed in a purple and blue light.

Large format
print solutions.

FOR PHOTOGRAPHY
& FINE ART

you can

Canon

Expand the realms of possibility and help your work spring to life in digital with Canon's Large Format Printers for photography and fine art applications.

Image quality makes a big impression.



imagePROGRAF



iPF5100

17"



iPF6300

24"



iPF6350

The finest results for: Professional Photographers and studios
General Print Service Providers

Digital Fine Artists and Fine Art
Productions specialists

Big benefits with Canon

Since we developed the first camera back in 1934, Canon have been at the forefront of digital image capture. Today, our digital SLRs are the first choice for many photography professionals. Creating large-scale digital fine art or photography requires considerable skill, so it's important to back it up with the technology that will ensure your work is seen in the best possible light. Our heritage and reputation in photography and ink jet printing results in a range of Large Format Printers that deliver in all areas.

A new LUCIA EX pigment ink system delivers increased accuracy and an extended colour range meeting the market demand for the most sophisticated print quality. And thanks to Canon's FINE technology and L-COA system architecture your finest creations are delivered at exceptional speeds.

The range

Canon's range of Large Format Printers for photography and fine art give you the confidence to deliver your best work every time. The 12-colour LUCIA / LUCIA EX ink systems delivers exceptionally accurate colours by including both RGB and CMYK inks. These innovative systems prove incredibly cost effective too as there's less of a need to blend colours to produce the results you desire, ensuring a sound return on your investment.

You'll find a comprehensive range encompassing 5 specialist devices - spanning A2 (17") up to 60" printing - that are incredibly easy to work with. Leaving you to focus all your attentions on those masterpieces in the making.

The expanding world of Large Format photography and digital fine art has never been better served than now. Canon's extensive range of specialist Large Format devices and media provides everything you need for today's outstanding productions and tomorrow's gallery showpieces.



iPF8300

44"



iPF9100

60"





The wider your imagination, the bigger the possibilities.

Imagine extending your photographic services portfolio with stunning large format production capabilities. Or finally being able to experience your finest art creations as centrepieces in the galleries that matter. We can help you make it happen.

Exceptional colour reproduction

The extra special results that your work demands is delivered with Canon's incredible 12-colour LUCIA / LUCIA EX pigment ink systems. The full spectrum of colours is produced with unnerving accuracy and perfect balance due to the inclusion of RGB and CMYK inks. A dual print head featuring 30,720 nozzles produces super-fine, evenly distributed 4 picolitre ink droplets.

Brilliant black and white photography

Capture those classic black and white shots with the benefit of high quality large format production values. A combination of black, matt black, grey and photo grey inks allow for incredibly lifelike photography with exceptional detail. Opening the door to numerous applications such as wedding photography, christenings, and the fast growing lifestyle portrait work.

Results that last forever

Prints are highly scratch resistant and unaffected by lighting variations, providing outstandingly consistent results for over 100 years.

Super quick performance

Using the highest quality 12-colour ink system doesn't mean you have to compromise productivity. Each printer is capable of extraordinary speeds. The iPF8300 can print A0 in 6 minutes, 31 seconds on to glossy photographic paper.

Easy to use

Device operation is simple thanks to a large LCD panel which provides clear menu-driven controls for all functions. Various types of Canon and third party media are handled giving you added flexibility for your artistic creations and photography. Potential media misalignment is virtually eradicated thanks to auto-skew correction which automatically adjusts for any skew in orientation and feeds the paper correctly. Plus, a thoughtfully designed fan system ensures the quietest of operation, ensuring your device is a pleasure to work with.

Truly cost effective

The 12-colour LUCIA / LUCIA EX ink systems also enable printing that's particularly economical. There is less need to blend colours (such as magenta and yellow to create red) and so less ink is required. Two grey inks are also included, further reducing the need to blend colours and keeping costs down. As you would expect from Canon, reliable performance is a given and for added peace of mind, our print heads feature a 12-month warranty.



The finest innovations create a huge impact.

Wherever your imagination takes you, we want you to be free to experience it with Canon. That's why we've invested heavily in research and development to produce a specialist photography and fine art range that fulfils your highest aspirations.

Innovative technology that breaks new boundaries.



Canon's latest LUCIA EX 12-colour ink systems*

Extensive research and fine-tuning has given birth to our latest LUCIA EX 12-colour pigment ink system, delivering the quality and speeds required for production and the precision needed for colour proofing applications.

A new formula of the pigments offers excellent colour reproduction and increases the colour gamut by around 20% over previous LUCIA versions.

LUCIA EX also delivers prints with denser, sharper blacks and smooth colour gradations, as well as the reproduction of the finest details in the shadow areas of photographs. The new inks are also designed with an innovative polymer structure that results in greater scratch resistance and protection from colour fading, while also reducing bronzing and metamerism to ensure durable, stable output.

Print with FINE technology

To deliver faithful image expression, ink droplets must be extremely small and precisely distributed. When droplets become microscopic however, image quality is affected by problems such as uneven droplet size and placement on the paper. Conventional printing systems compensate by making multiple passes for each line but this adds significantly to print times.

Canon's FINE (Full photolithograph Inkjet Nozzle Engineering) overcomes this problem without needing to make multiple passes, producing bi-directional printing at incredible speeds. An innovated ink-nozzle manufacturing method results in precisely uniform droplets and outstanding photo-quality print performance.

High precision photo mode*

Choose this feature for the very finest results required by artists and photographers. Specific technology controls ink placement according to the ink's characteristics resulting in superb contrasts and detailed gradation in dark areas.

Vibration free structure*

By redesigning the mechanical structure of the device the minutest vibrations have been cut which means that the frame is resistant to any vibration caused during scanning thus enhancing ink placement and accuracy.

* Available only on IPF6300 / IPF6350 / IPF8300

Canon's FINE technology

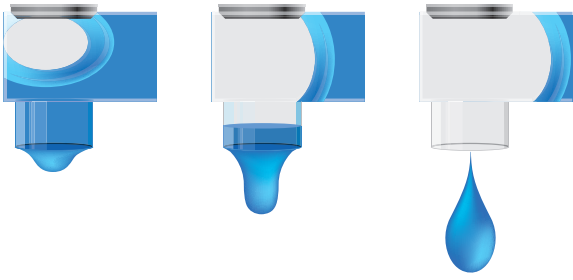

Canon's FINE technology uses ink bubbles that are formed at the top of the nozzle to separate and eject the ink.

Kyuanos Colour Management

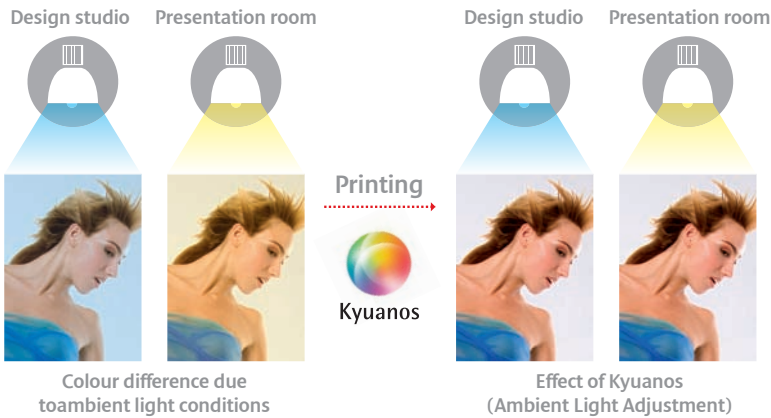

L-COA for unbeatable productivity

Providing the optimal balance between high productivity and high quality is Canon's Large Format Printer Common Architecture (L-COA). L-COA helps your printer carry out the most complex print jobs with ease.

Colour Management with KYUANOS

A next generation colour management system is featured in the imagePROGRAF printer driver and in the optional PosterArtist 2009 software. KYUANOS helps ensure optimal results for media that's to be used across varying light conditions. This enables you to compensate for colours before printing, depending on the viewing environment, to ensure optimum colour reproduction in the finished prints.

Advanced Colour Calibration

A powerful colour calibration system ensures the most stable colour reproduction attainable. In conventional systems, changing the print heads may cause a minute variation in print output, due to the density characteristics of the print head. With Canon's Advanced Colour Calibration, a multi-sensor measures variations in density on a printed calibration chart and then automatically applies any appropriate adjustment to ensure an exact match for long-term consistency.

With five specialist devices, Canon's photography and fine art printer range offers the flexibility of choice you need to bring all your most ambitious ideas to life.

A wide range provides everything you need.

Media matters

More choice and better quality for you and your customers comes courtesy of Canon's exclusive range of specialist media. Designed for Large Format Printing applications we offer 40 high quality specialist options for photography, fine art, proofing, CAD & GIS and production sectors.

For photography there are additional media's including satins and glossy photo paper. For fine art applications there are specialist media including embossed paper and water resistant canvas. A diversity of weights and roll widths are available giving maximum choice.

Some models* now allow not only Canon media but also to add and make adjustments to paper settings to enhance the precision quality of your output with third party media. The entire Canon range is supported with ICC profiles. Compatible ICC profiles of popular media types from Hahnemuehle, Ilford and Sihl can be downloaded.

Quality results with Canon inks

We're constantly looking to fine-tune the quality of our inks and thereby the quality of your prints. That's why we've developed the 12-colour LUCIA / LUCIA EX pigment ink systems to give the best results in the applications you need them for. For fine art creations and photography work you need the widest colour gamut and the most accurate and expressive colours, so make sure you choose Canon's LUCIA inks - specifically developed for this purpose.

Photography and fine art media roll widths available

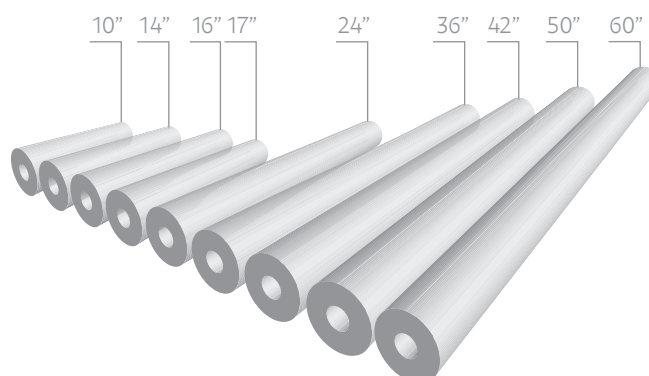

1. 12 colour LUCIA pigment ink system

For outstanding image expression and superb colour reproduction

2. Reduced graininess

With optimum results across all media types

3. Fast production

6 minutes, 31 seconds on photographic paper (glossy) A0

4. Borderless printing

Up to 44" in size

5. Auto Skew Correction

For trouble-free printing

6. 'Hot Swap' ink tanks

For continuous production (iPF8300 and iPF9100)

7. Powerful software

To help with your creations

8. 80GB HDD

As standard (iPF6350, iPF8300 and iPF9100)

9. Large LCD control panel

Makes operation quick and simple with fast error recovery

10. Cost efficient printing

With 12 colours due to less colour blending

11. High precision photo mode

iPF8300



! The finest results with Canon Inks and Media.

Effortless control

Ultimate control comes courtesy of Canon's flexible imagePROGRAF Printer Driver.

An "easy mode" allows you to use Canon's pre-defined settings for speed and simplicity of use. Switch to "advanced mode" however and you can adjust drying times, colour settings and manage your own ICC profiles.

Page set-up provides pure flexibility allowing customised page sizes if required and a best-fit option for each media is selectable. Select the watermark feature and you can protect the rights of your images. For enhanced workflow, pre-defined settings can be created using hot folders.

A maintenance facility allows you to adjust the media feed, do a nozzle check, clean the print heads, check the queue and carry out other timesaving procedures.

Digital Photo Front Access

This useful application allows you to import digital photos from your digital camera.

Intuitive software allows you to easily edit photos before printing and also enables you to link with other applications such as Adobe Photoshop and Canon PosterArtist.

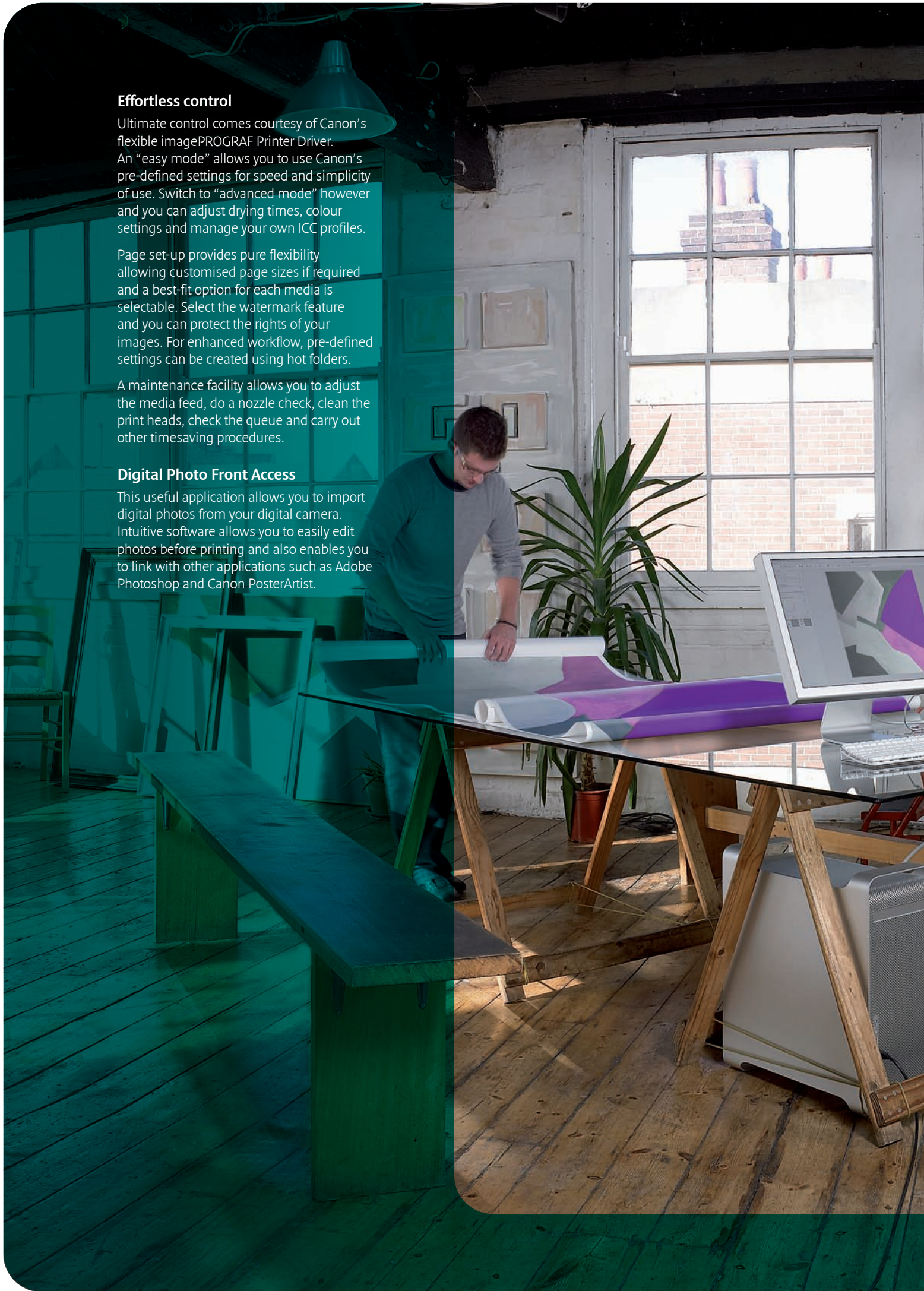

Expand your possibilities.

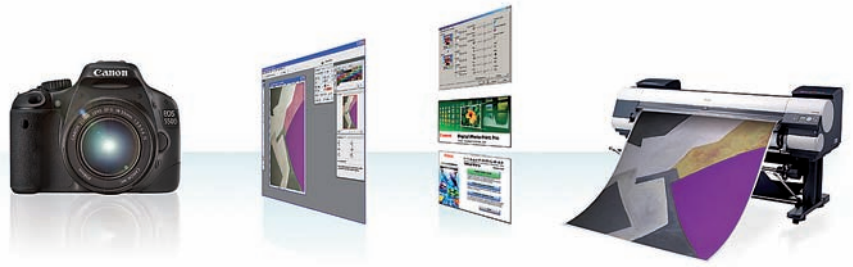

Powerful software helps you think big.

We work hard to understand how your business works. In doing so we're able to develop products that match your highest expectations and added value software that helps you explore your ambitions to the full.

Plug-In for Digital Photo Professional

Professional photographers benefit from direct links to Canon's Digital Photo Professional software which is included with our range of digital EOS SLR cameras.

Create incredible posters

It's also possible to use your printer for entirely different means. Opt for Canon's PosterArtist 2009 software and you can use it to create incredible borderless posters, signs and displays. Select from a wide range of pre-defined templates or create your own.

Plug-In for Photoshop

To expand print options and improve proofing capabilities, the iPF8300, iPF6350 and iPF6300 come bundled with a new Print Plug-In for Adobe Photoshop® and Canon's EOS Digital Photo Professional application. This now supports the Adobe Colour Management Module, enabling features such as Black Point Compensation. Through the Plug-In, each new model allows 16-bit RGB images edited in Adobe Photoshop and Canon's EOS Digital Photo Professional application to be sent directly to the imagePROGRAF printers, preserving smooth and high gradation.

Explore huge possibilities with Canon.

Some images are simulated for clarity of reproduction. All data is based on Canon's standard testing methods. This leaflet and the specifications of the product have been developed prior to the date of product launch. Final specifications are subject to change without notice.™ and ©: All company and/or product names are trademarks and/or registered trademarks of their respective manufacturers in their markets and/or countries.

Canon recommends you use Canon Media for the best results. Please check media (paper) compatibility list to see which variety of paper/media is recommended.



Canon Inc.
www.canon.com

Canon Europa
www.canon-europe.com

English-UK Edition 0145W569
© Canon Europa N.V., 2010 (0610)

Canon (UK) Ltd
Woodhatch, Reigate
Surrey RH2 8BF
Tel: 01737 220000
Fax: 01737 220022
www.canon.co.uk

Canon Ireland
Arena Road, Sandford
Industrial Estate
Dublin 18, Ireland
Tel: 01 2052400
Fax: 01 2958141
www.canon.ie

Canon