

BASIC SERIAL COMMAND FUNCTIONAL SPECIFICATIONS

LV-7585

Ver.1.1

SANYO Electric Co., Ltd
Personal Mobile Group
DI Company
Projector Business Division

Contents

1. Overview	4
2. Serial Interface Specification	4
2.1. Transfer Specification	4
2.2. Connection	4
3. Notes for Communication	5
4. Functional Execution Command Table	6
5. Status Read Command Table	7
6. Functional Execution Command	8
6.1 Format	8
6.2 When the command pipelining is needed	8
6.3 Transfer Example	8
6.4 Operation Requirements	9
6.5 POWER ON Command	9
6.6 POWER OFF Command (Quick POWER OFF)	9
6.7 POWER OFF Command	9
6.8 INPUT 1 Command	10
6.9 INPUT 2 Command	10
6.10 INPUT 3 Command	10
6.11 NETWORK Command	10
6.12 VIDEO MUTE ON Command	10
6.13 VIDEO MUTE OFF Command	11
6.14 SCREEN NORMAL SIZE Command	11
6.15 SCREEN WIDE SIZE Command	11
6.16 MENU ON Command	11
6.17 MENU OFF Command	11
6.18 DISPLAY CLEAR Command	11
6.19 BRIGHTNESS + Command	12
6.20 BRIGHTNESS - Command	12
6.21 INPUT 2 VIDEO Command	12
6.22 INPUT 2 Y,Pb/Cb,Pr/Cr Command	12
6.23 INPUT 2 RGB Command	12
6.24 IMAGE Command	12
6.25 ON START SET Command	12
6.26 ON START CANCEL Command	13
6.27 POWER MANAGEMENT READY Command	13
6.28 POWER MANAGEMENT CANCEL Command	13
6.29 POWER MANAGEMENT SHUTDOWN Command	13
6.30 D.ZOOM + Command	13
6.31 D.ZOOM - Command	13

6.32	INPUT 3 VIDEO Command	14
6.33	INPUT 3 S-VIDEO Command	14
6.34	INPUT 3 Y,Pb/Cb,Pr/Cr Command	14
6.35	POINTER RIGHT Command	14
6.36	POINTER LEFT Command	14
6.37	POINTER UP Command	14
6.38	POINTER DOWN Command	14
6.39	ENTER Command	15
6.40	FREEZE ON Command	15
6.41	FREEZE OFF Command	15
6.42	ZOOM + Command	15
6.43	ZOOM - Command	15
6.44	FOCUS + Command	15
6.45	FOCUS - Command	16
6.46	COLOR MANAGEMENT Command	16
6.47	INPUT 1 ANALOG RGB Command	16
6.48	INPUT 1 SCART Command	16
6.49	INPUT 1 DVI (PC DIGITAL) Command	16
6.50	INPUT 1 DVI (AV HDCP) Command	16
6.51	LENS SHIFT UP Command	17
6.52	LENS SHIFT DOWN Command	17
6.53	LENS SHIFT LEFT Command	17
6.54	LENS SHIFT RIGHT Command	17
6.55	AUTO PC ADJ. Command	17
6.56	PRESENTATION TIMER Command	17
6.57	KEYSTONE ↑ Command	18
6.58	KEYSTONE ↓ Command	18
6.59	KEYSTONE → Command	18
6.60	KEYSTONE ← Command	18
7	Status Read Command	19
7.1	Format	19
7.2	Transfer Example	19
7.3	Status Read Command	20
7.4	Input Mode Read Command	22
7.5	Lamp Time Read Command	22
7.6	Setting Read Command	22
7.7	Temp Read Command	23
7.8	Lamp Mode Read Command	23

LV-7585 Basic Serial Command Functional Specifications

1. Overview

- These specifications define projector control commands for LV-7585.
- The projector control commands are used to control a projector through RS-232C from a computer.

2. Serial Interface Specification

2.1. Transfer Specification

Item	Specification
Synchronous system	Asynchronous
Transmission Speed	9600 / 19200
Data Length	8 bits
Parity	None
Stop Bit	1
Flow Control	None

- ① Transmission speed: initial setting value is 19200.
- ② Transmission speed can be changed in service mode.

2.2. Connection

Dedicated serial cable that comes with the projector must be used for the connection between computer and projector.

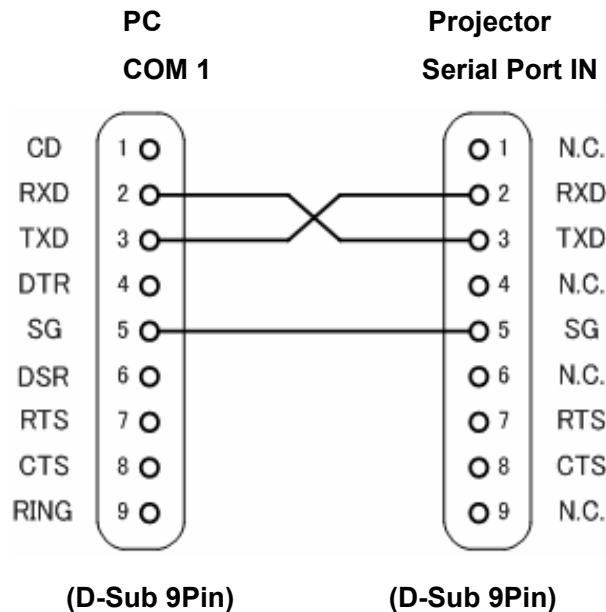

Connect COM port of the computer to SERIAL PORT IN of the projector.

COM Port (COM1 or COM2) of a computer is specified by control software of the computer.

3. Notes for Communication

- The projector command is defined as one command per line that starts with “C” and ends with carriage return (0x0D).
- When carriage return (0x0D) is received, decoding starts.
- There are two types of commands; Functional Execution Commands which function in a way comparable to remote and console keys and Status Read Commands which get basic statuses of projector.

Example of Functional Execution Command: “C05” [CR]

Example of Status Read Command: “CR0” [CR]

- In the cases below, it clears information of receive buffer.
 - 1) When LF (0x0A) and EOF (0x1A) are received
 - 2) When it takes more than a second to receive one command (until the projector receives carriage return since it has received the first data)
- or the pipelining of Functional Execution Command, allow the following interval time after receiving return value.
 - 1) Commands “VOLUME +/-“, “ZOOM UP/DOWN“, “FOCUS UP/DOWN” and “LENS-SHIFT UP/DOWN/RIGHT” --> 100ms
 - 2) Other commands --> 500ms
- For the pipelining of Status Read Command, allow more than 500 ms of interval time after reception of return value.
- Do not send any subsequent command before reception of return value; however this is not the case when no response is returned after more than 5 seconds.
- It takes about 7 seconds for internal initialization after plugging in AC power. During this time, it cannot process commands. Do not issue any command.
- During 7 seconds after powering on in Standby mode, when the command for internal initialization or lamp lighting is received, ACK value is returned but the function is not executed. However, for Status Read Command, the function is executed in 500 ms after receiving ACK value for POWER ON command.
- During countdown and cooling operations:

During countdown operation after execution of power-on, as well as during cooling operation after execution of power-off, ACK value is returned but the function is not executed when command is received.
- On switching INPUT:

During 5 seconds after switching action has started in response to reception of INPUT switching command, ACK value is returned but the function is not executed when command is received. However, for Status Read Command, the function is executed in 500 ms after receiving ACK value for INPUT switching command.
- The number of characters indicating successful reception of command varies according to the command. Please see [7. Status Read Command].
- Characters used for commands must be Capital (A - Z).

4. Functional Execution Command Table

Command	Item	Command	Item
C00	POWER ON	C20	BRIGHTNESS +
C01	POWER OFF (QUICK POWER OFF)	C21	BRIGHTNESS -
C02	POWER OFF	C22	---
C03	---	C23	INPUT 2 VIDEO
C04	---	C24	INPUT 2 Y,Pb/Cb,Pr/Cr
C05	INPUT 1	C25	INPUT 2 RGB
C06	INPUT 2	C26	---
C07	INPUT 3	C27	IMAGE
C08	NETWORK	C28	ON START Enable
C09	---	C29	ON START Disable
C0A	---	C2A	POWER MANAGEMENT READY
C0B	---	C2B	POWER MANAGEMENT OFF
C0C	---	C2C	---
C0D	VIDEO MUTE ON	C2D	---
C0E	VIDEO MUTE OFF	C2E	POWER MANAGEMENT SHUT DOWN
C0F	SCREEN NORMAL SIZE (4:3)	C2F	---
C10	SCREEN WIDE SIZE (16:9)	C30	D.ZOOM +
C11	---	C31	D.ZOOM -
C12	---	C32	---
C13	---	C33	INPUT 3 VIDEO
C14	---	C34	INPUT 3 S-VIDEO
C15	---	C35	INPUT 3 Y,Pb/Cb,Pr/Cr
C16	---	C36	---
C17	---	C37	---
C18	---	C38	---
C19	---	C39	---
C1A	---	C3A	POINTER RIGHT
C1B	---	C3B	POINTER LEFT
C1C	MENU ON	C3C	POINTER UP
C1D	MENU OFF	C3D	POINTER DOWN
C1E	DISPLAY CLEAR	C3E	---
C1F	---	C3F	ENTER

“---“ means “No Function”.

LV-7585 Basic Serial Command Functional Specifications

Command	Item	Command	Item
C40	---	C80	---
C41	---	C81	---
C42	---	C82	---
C43	FREEZE ON	C83	---
C44	FREEZE OFF	C84	---
C45	---	C85	---
C46	ZOOM -	C86	---
C47	ZOOM +	C87	---
C48	---	C88	---
C49	---	C89	AUTO PC ADJ
C4A	FOCUS -	C8A	PRESENTATION TIMER
C4B	FOCUS +	C8B	---
C4C	---	C8C	---
C4D	---	C8D	---
C4E	COLOR MANAGEMENT	C8E	KEYSTONE ↑
C4F	---	C8F	KEYSTONE ↓
C50	INPUT 1 ANALOG RGB	C90	KEYSTONE →
C51	INPUT 1 SCART	C91	KEYSTONE ←
C52	INPUT 1 DVI (PC DIGITAL)	C92	---
C53	INPUT 1 DVI (AV HDCP)	C93	---
C54	---	C94	---
C55	---	C95	---
C56	---	C96	---
C57	---	C97	---
C58	---	C98	---
C59	---	C99	---
C5A	---	C9A	---
C5B	---	C9B	---
C5C	---	C9C	---
C5D	Lens Shift Up	C9D	---
C5E	Lens Shift Down	C9E	---
C5F	Lens Shift Left	C9F	---
C60	Lens Shift Right		

“---” means “No Function”

5. Status Read Command Table

Command	Item	Note
CR0	STATUS READ	
CR1	INPUT MODE READ	
CR2	---	
CR3	LAMP TIME READ	
CR4	SETTING READ	
CR5	---	
CR6	TEMP READ	
CR7	LAMP MODE READ	
CRC	---	

“---” means “No Function”.

6. Functional Execution Command

6.1 Format

- PC issues a command in the following format:

“C” **Command** [CR]

Command: two characters (See Functional Execution Command Table)

- Projector decodes the received data and returns the result when getting ready to receive the next command.

[ACK] [CR] : (0x06, 0x0D) When received Functional Execution Commands.

- When received data cannot be decoded, “?” [CR] is returned.

6.2 When the command pipelining is needed

In the case of the function requiring command pipelining, such as “Volume +/-” and “Zoom +/-”, operation should follow the same way as in remote control:

- 1) Sending-side system issues commands every 100 ms after receiving the return value.
- 2) When receiving an applicable command, the function is executed for 120 ms from the moment.
- 3) When receiving the same command in sequence within 120 ms, the function is executed for another 120 ms from the moment of the second command reception.
- 4) When any other command is not received after 120 ms, the execution of pipelining is stopped.
- 5) When Projector receives another command within 120 ms, the execution of pipelining is stopped.

6.3 Transfer Example

Change Projector mode to Video with Basic Command.

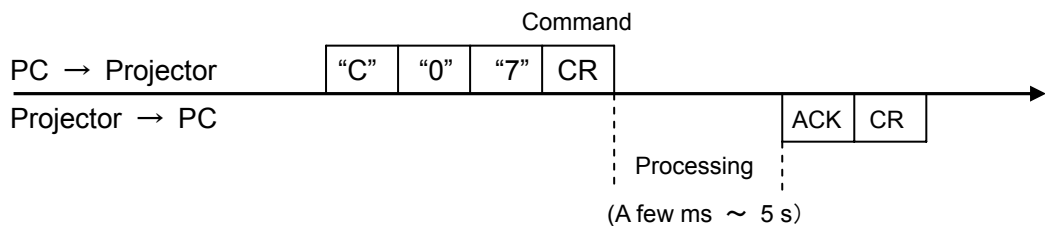

6.4 Operation Requirements

In the following status of projector, Available Functional Execution Commands are limited.

Projector Status	Available Functional Execution Commands
Standby Mode	C00: POWER ON
Countdown in process	C00: POWER ON → Countdown is terminated C01: POWER OFF C02: POWER OFF → Countdown is terminated C46: ZOOM - C47: ZOOM + C4A: FOCUS - C4B: FOCUS + C5D: LENS SHIFT UP C5E: LENS SHIFT DOWN C5F:LENS SHIFT LEFT C60:LENS SHIFT RIGHT
Cooling Down in process	NONE (No Execution)
Cooling Down due to Abnormal Temperature	NONE (No Execution)
Abnormal Temperature Status	NONE (No Execution)
Abnormal Power Status	NONE (No Execution)
Abnormal Filter Status	NONE (No Execution)
Power-Save Cooling Down in process	NONE (No Execution)
Power Save Status	C00: POWER ON C01: POWER OFF
Cooling Down in process after OFF operation due to Lamp Failure	NONE (No Execution)

Note) in above status, the projector returns [ACK] [CR] even if it receives the other command.

6.5 POWER ON Command

Command	"C00" [CR]	
Detail	Power ON When already Power is ON, no operation is started. When sending this command during Countdown in process, Countdown is terminated.	
Response	Acceptable	[ACK] [CR]
	Unacceptable	"?" [CR]

6.6 POWER OFF Command (Quick POWER OFF)

Command	"C01" [CR]	
Detail	Power OFF (Standby) This command executes Quick Power OFF operation without displaying "Power OFF?" message, which is displayed when Power is turned OFF with ON/STAND-BY button of the projector or remote control.	
Response	Acceptable	[ACK] [CR]
	Unacceptable	"?" [CR]

6.7 POWER OFF Command

Command	"C02" [CR]	
Detail	Power OFF (Standby) This command works the same way as when Power is OFF with ON/STAND-BY button of the projector and remote control. (When the command is sent once, "Power OFF?" message is displayed. If this command is sent again while "Power OFF?" message is displayed, Power OFF operation is executed.) When sending this command during Countdown in process, Countdown is terminated.	

Response	Acceptable	[ACK] [CR]
	Unacceptable	"?" [CR]

6.8 INPUT 1 Command

Command	"C05" [CR]	
Detail	Select Input 1. This command works differently from the command by "Input 1" key of the remote control. When Input 1 has been already selected, this command does not execute the source switching; just for switching to Input 1.	
Response	Acceptable	[ACK] [CR]
	Unacceptable	"?" [CR]

6.9 INPUT 2 Command

Command	"C06" [CR]	
Detail	Select Input 2. This command works differently from the command by "Input 2" key of the remote control. When Input 2 has been selected, this command does not execute the source switching; just for switching to Input 2.	
Response	Acceptable	[ACK] [CR]
	Unacceptable	"?" [CR]

6.10 INPUT 3 Command

Command	"C07" [CR]	
Detail	Select Input 3. This command works differently from the command by "Input 3" key of the remote control. When Input 3 has been selected, this command does not execute the source switching; just for switching to Input 3.	
Response	Acceptable	[ACK] [CR]
	Unacceptable	"?" [CR]

6.11 NETWORK Command

Command	"C08" [CR]	
Detail	Select Network Input	
Response	Acceptable	[ACK] [CR]
	Unacceptable	"?" [CR]

6.12 VIDEO MUTE ON Command

Command	"C0D" [CR]	
Detail	Video Mute ON This command works the same way as "NO SHOW" button of the remote control for No Show ON, but does not work for No Show OFF.	
Response	Acceptable	[ACK] [CR]
	Unacceptable	"?" [CR]

6.13 VIDEO MUTE OFF Command

Command	"C0E" [CR]	
Detail	Video Mute OFF This command works the same way as "NO SHOW" button of remote control for No Show OFF, but does not work for No Show ON.	
Response	Acceptable	[ACK] [CR]
	Unacceptable	"?" [CR]

6.14 SCREEN NORMAL SIZE Command

Command	"C0F" [CR]	
Detail	Set screen size to Normal (4:3)	
Response	Acceptable	[ACK] [CR]
	Unacceptable	"?" [CR]

6.15 SCREEN WIDE SIZE Command

Command	"C10" [CR]	
Detail	Set screen size to Wide (16:9)	
Response	Acceptable	[ACK] [CR]
	Unacceptable	"?" [CR]

6.16 MENU ON Command

Command	"C1C" [CR]	
Detail	Display On-Screen Display Menu	
Response	Acceptable	[ACK] [CR]
	Unacceptable	"?" [CR]

6.17 MENU OFF Command

Command	"C1D" [CR]	
Detail	Clear On-Screen Display Menu	
Response	Acceptable	[ACK] [CR]
	Unacceptable	"?" [CR]

6.18 DISPLAY CLEAR Command

Command	"C1E" [CR]	
Detail	Clear On-Screen Display Clear On-screen Display under all conditions	
Response	Acceptable	[ACK] [CR]
	Unacceptable	"?" [CR]

6.19 BRIGHTNESS + Command

Command	"C20" [CR]	
Detail	Increment Brightness by 1 according to user control.	
Response	Acceptable	[ACK] [CR]
	Unacceptable	"?" [CR]

6.20 BRIGHTNESS - Command

Command	"C21" [CR]	
Detail	Decrement Brightness by 1 according to user control.	
Response	Acceptable	[ACK] [CR]
	Unacceptable	"?" [CR]

6.21 INPUT 2 VIDEO Command

Command	"C23" [CR]	
Detail	Select Video input in Input 2	
Response	Acceptable	[ACK] [CR]
	Unacceptable	"?" [CR]

6.22 INPUT 2 Y,Pb/Cb,Pr/Cr Command

Command	"C24" [CR]	
Detail	Select Y,Pb/Cb,Pr/Cr input in Input 2	
Response	Acceptable	[ACK] [CR]
	Unacceptable	"?" [CR]

6.23 INPUT 2 RGB Command

Command	"C25" [CR]	
Detail	Select RGB input in Input 2	
Response	Acceptable	[ACK] [CR]
	Unacceptable	"?" [CR]

6.24 IMAGE Command

Command	"C27" [CR]	
Detail	Switch Image Setting status	
Response	Acceptable	[ACK] [CR]
	Unacceptable	"?" [CR]

6.25 ON START SET Command

Command	"C28" [CR]	
Detail	Enable Power ON Start This status is stored in EEPROM and retained regardless of Power OFF/ON operation.	
Response	Acceptable	[ACK] [CR]
	Unacceptable	"?" [CR]

6.26 ON START CANCEL Command

Command	"C29" [CR]	
Detail	Disable Power ON Start This status is stored in EEPROM and retained regardless of Power OFF/ON operation.	
Response	Acceptable	[ACK] [CR]
	Unacceptable	"?" [CR]

6.27 POWER MANAGEMENT READY Command

Command	"C2A" [CR]	
Detail	Set Power Management function to ready status This status is stored in EEPROM and retained regardless of Power OFF/ON operation.	
Response	Acceptable	[ACK] [CR]
	Unacceptable	"?" [CR]

6.28 POWER MANAGEMENT CANCEL Command

Command	"C2B" [CR]	
Detail	Set Power Management function to off status This status is stored in EEPROM and retained regardless of Power OFF/ON operation.	
Response	Acceptable	[ACK] [CR]
	Unacceptable	"?" [CR]

6.29 POWER MANAGEMENT SHUTDOWN Command

Command	"C2E" [CR]	
Detail	Set Power Management function to Shutdown mode. This status is stored in EEPROM and retained regardless of Power OFF/ON operation.	
Response	Acceptable	[ACK] [CR]
	Unacceptable	"?" [CR]

6.30 D.ZOOM + Command

Command	"C30" [CR]	
Detail	Enter Digital Zoom mode and expand image size This command works the same way as "D.ZOOM ▲" button of the remote control.	
Response	Acceptable	[ACK] [CR]
	Unacceptable	"?" [CR]

6.31 D.ZOOM - Command

Command	"C31" [CR]	
Detail	Enter Digital Zoom mode and reduce image size This command works the same as "D.ZOOM ▼" button of the remote control.	
Response	Acceptable	[ACK] [CR]
	Unacceptable	"?" [CR]

6.32 INPUT 3 VIDEO Command

Command	"C33" [CR]	
Detail	Select Video input in Input 3	
Response	Acceptable	[ACK] [CR]
	Unacceptable	"?" [CR]

6.33 INPUT 3 S-VIDEO Command

Command	"C34" [CR]	
Detail	Select S-Video input in Input 3	
Response	Acceptable	[ACK] [CR]
	Unacceptable	"?" [CR]

6.34 INPUT 3 Y,Pb/Cb,Pr/Cr Command

Command	"C35" [CR]	
Detail	Select Y,Pb/Cb,Pr/Cr input in Input 3	
Response	Acceptable	[ACK] [CR]
	Unacceptable	"?" [CR]

6.35 POINTER RIGHT Command

Command	"C3A" [CR]	
Detail	Move the Pointer of On-Screen Display Menu to the right. This command works differently from the command by Point button ">" of the projector and has no "Volume +" function.	
Response	Acceptable	[ACK] [CR]
	Unacceptable	"?" [CR]

6.36 POINTER LEFT Command

Command	"C3B" [CR]	
Detail	Move the Pointer of On-Screen Display Menu to the left This command works differently from the command by Point button "<" of the projector and has no "Volume -" function.	
Response	Acceptable	[ACK] [CR]
	Unacceptable	"?" [CR]

6.37 POINTER UP Command

Command	"C3C" [CR]	
Detail	Move up the Pointer of On-Screen Display Menu This command works the same way as "▲" button of the projector.	
Response	Acceptable	[ACK] [CR]
	Unacceptable	"?" [CR]

6.38 POINTER DOWN Command

Command	"C3D" [CR]	
---------	------------	--

Detail	Move down the Pointer of On-Screen Display Menu This command works the same way as “▼” button of the projector.	
Response	Acceptable	[ACK] [CR]
	Unacceptable	“?” [CR]

6.39 ENTER Command

Command	“C3F” [CR]	
Detail	This command works the same way as “SELECT” button of the projector and remote control.	
Response	Acceptable	[ACK] [CR]
	Unacceptable	“?” [CR]

6.40 FREEZE ON Command

Command	“C43” [CR]	
Detail	Freeze on-screen image This command works the same way as “FREEZE” button of the remote control for Freeze ON, but does not work for Freeze OFF.	
Response	Acceptable	[ACK] [CR]
	Unacceptable	“?” [CR]

6.41 FREEZE OFF Command

Command	“C44” [CR]	
Detail	Cancel Freeze mode This command works the same way as “FREEZE” button of the remote control for Freeze Off, but does not work for Freeze ON.	
Response	Acceptable	[ACK] [CR]
	Unacceptable	“?” [CR]

6.42 ZOOM + Command

Command	“C47” [CR]	
Detail	Expand image size This command works the same way as “ZOOM ▲” button of the remote control.	
Response	Acceptable	[ACK] [CR]
	Unacceptable	“?” [CR]

6.43 ZOOM - Command

Command	“C46” [CR]	
Detail	Reduce image size This command works the same way as “ZOOM ▼” button of the remote control.	
Response	Acceptable	[ACK] [CR]
	Unacceptable	“?” [CR]

6.44 FOCUS + Command

Command	“C4B” [CR]	
Detail	Adjust on-screen focus by making focal length longer. (The lens moves backward) This command works the same way as “FOCUS ▲” button of the remote control.	

Response	Acceptable	[ACK] [CR]
	Unacceptable	"?" [CR]

6.45 FOCUS - Command

Command	"C4A" [CR]	
Detail	Adjust on-screen focus by making focal length shorter. (The lens moves forward) This command works the same way as "FOCUS ▼" button of the remote control.	
Response	Acceptable	[ACK] [CR]
	Unacceptable	"?" [CR]

6.46 COLOR MANAGEMENT Command

Command	"C4E" [CR]	
Detail	Enable Color Management function	
Response	Acceptable	[ACK] [CR]
	Unacceptable	"?" [CR]

6.47 INPUT 1 ANALOG RGB Command

Command	"C50" [CR]	
Detail	Select Analog RGB input in Input 1	
Response	Acceptable	[ACK] [CR]
	Unacceptable	"?" [CR]

6.48 INPUT 1 SCART Command

Command	"C51" [CR]	
Detail	Select SCART input in Input 1	
Response	Acceptable	[ACK] [CR]
	Unacceptable	"?" [CR]

6.49 INPUT 1 DVI (PC DIGITAL) Command

Command	"C52" [CR]	
Detail	Select DVI (PC Digital) input in Input 1	
Response	Acceptable	[ACK] [CR]
	Unacceptable	"?" [CR]

6.50 INPUT 1 DVI (AV HDCP) Command

Command	"C53" [CR]	
Detail	Select DVI (AV HDCP) input of Input 1	
Response	Acceptable	[ACK] [CR]
	Unacceptable	"?" [CR]

6.51 LENS SHIFT UP Command

Command	"C5D" [CR]	
Detail	Move projection area upward.	
Response	Acceptable	[ACK] [CR]
	Unacceptable	"?" [CR]

6.52 LENS SHIFT DOWN Command

Command	"C5E" [CR]	
Detail	Move projection area downward.	
Response	Acceptable	[ACK] [CR]
	Unacceptable	"?" [CR]

6.53 LENS SHIFT LEFT Command

Command	"C5F" [CR]	
Detail	Move projection area leftward.	
Response	Acceptable	[ACK] [CR]
	Unacceptable	"?" [CR]

6.54 LENS SHIFT RIGHT Command

Command	"C60" [CR]	
Detail	Move projection area rightward.	
Response	Acceptable	[ACK] [CR]
	Unacceptable	"?" [CR]

6.55 AUTO PC ADJ. Command

Command	"C89" [CR]	
Detail	Execute AUTO PC ADJ. function This command works the same way as "AUTO PC ADJ." button of the remote control. Sending this command during Auto PC Adj. process terminates the operation. This is the same by "AUTO PC" button of the remote control.	
Response	Acceptable	[ACK] [CR]
	Unacceptable	"?" [CR]

6.56 PRESENTATION TIMER Command

Command	"C8A" [CR]	
Detail	Start Timer for presentation This command works the same way as "P-TIMER" button of the remote control.	
Response	Acceptable	[ACK] [CR]
	Unacceptable	"?" [CR]

6.57 KEYSTONE ↑ Command

Command	"C8E" [CR]	
Detail	Correct keystone distortion by reducing upper part of image. This command invokes both operations of keystone distortion correction and OSD display, regardless of whether the "KEYSTONE" OSD has been already displayed or not.	
Response	Acceptable	[ACK] [CR]
	Unacceptable	"?" [CR]

6.58 KEYSTONE ↓ Command

Command	"C8F" [CR]	
Detail	Correct keystone distortion by reducing lower part of image. This command invokes both operations of keystone distortion correction and OSD display, regardless of whether the "KEYSTONE" OSD has been already displayed or not.	
Response	Acceptable	[ACK] [CR]
	Unacceptable	"?" [CR]

6.59 KEYSTONE → Command

Command	"C90" [CR]	
Detail	Correct keystone distortion by reducing right side of image. This command invokes both operations of keystone distortion correction and OSD display, regardless of whether the "KEYSTONE" OSD has been already displayed or not.	
Response	Acceptable	[ACK] [CR]
	Unacceptable	"?" [CR]

6.60 KEYSTONE ← Command

Command	"C91" [CR]	
Detail	Correct keystone distortion by reducing left side of image. This command invokes both operations of keystone distortion correction and OSD display, regardless of whether the "KEYSTONE" OSD has been already displayed or not.	
Response	Acceptable	[ACK] [CR]
	Unacceptable	"?" [CR]

7 Status Read Command

7.1 Format

- PC issues a command in the following format.

“CR” Command [CR]

Command: one character (See Status Read Command Table)

- When projector receives an appropriate command, it returns the required data in string.

Required Data [CR]

Required Data: string (See Status Read Command Table)

- When the received data cannot be decoded, the projector returns “?” [CR] is returned.

7.2 Transfer Example

Getting Input mode information of projector by Basic Commands.

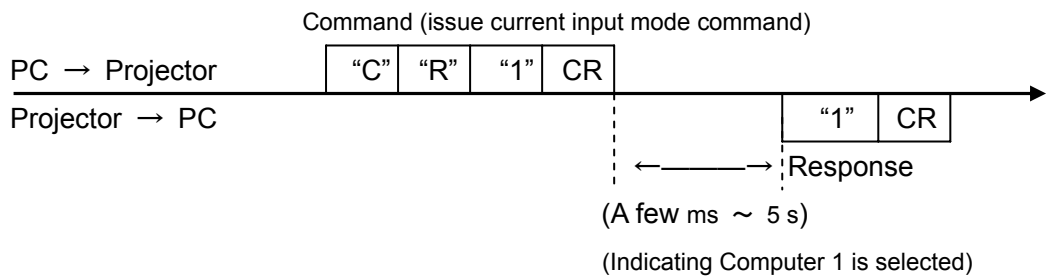

7.3 Status Read Command

Command	"CR0" [CR]	
Detail	Get the projector's operating status	
Response	Acceptable	"%1" [CR]
	%1	"00" = Power ON "80" = Standby "40" = Countdown in process "20" = Cooling Down in process "10" = Power Failure "28" = Cooling Down in process due to Abnormal Temperature "88" = Standby after Cooling Down due to Abnormal Temperature "24" = Power-Save Cooling Down in process "04" = Power Save "21" = Cooling Down in process after OFF due to Lamp Failure "81" = Standby after Cooling Down due to Lamp Failure
	Unacceptable	"?" [CR]

[Details for Response]

- **"00" [CR]**
 Status: Power ON
 Normal image is on-screen.
- **"80" [CR]**
 Status: Standby
 When the status is Standby, Status Read Commands are always accepted, but any Functional Execution Commands are not accepted except for POWER ON command.
- **"40" [CR]**
 Status: Countdown in process
 When "Display" in Setting Menu is set to ON, Countdown operation is started by execution of POWER ON; while "Display" in Setting Menu is set to OFF, the status moves directly to Power ON without Countdown operation.
- **"20" [CR]**
 Status: Cooling Down in process
 When the status is Power ON, and then POWER OFF Command ("C01" [CR]) is executed, it moves to Cooling Down status.
 When lamp turns off and about 90 seconds of fan spinning finishes, the above status automatically moves to Standby (The fan spinning time depends on models.)
 This function is intended to cool down lamps and other optical parts, and is quite important for projector's reliability. During this time, any Functional Execution Command is invalid.
- **"10" [CR]**
 Status: Power Failure
 When the power supply voltage inside the projector reaches abnormal status, the projector is automatically turned off. ※Projector perform the same when filter abnormal status

occurs.

The projector returns "10" [CR], which indicates it enters Power OFF status due to Power Failure.

In this case Fan also stops unlike Cooling Down status.

- **"28" [CR]**

Status: Cooling Down in process due to Abnormal Temperature

When the inside temperature rises abnormally high, it automatically starts Cooling Down operation. The projector returns "28" [CR].

Even if the temperature goes down during this process, the given Cooling Down process is conducted.

- **"88" [CR]**

Status: Standby after Cooling Down due to Abnormal Temperature

When the status becomes Standby after the temperature goes down by Cooling Down operation invoked due to Abnormal Temperature, the projector returns "88" [CR]. This indicates Abnormal Temperature caused turning to Standby status.

This status continues until the next operation is started; when Power On is executed, the projector clears the information of Abnormal Temperature and normal operation starts.

- **"24" [CR]**

Status: Power-Save Cooling Down in process

This indicates Power Management in the Setting menu is enabled and Power-Save Cooling Down operation is in process.

During this time, any Functional Execution Command is invalid.

In this Power-Save Cooling Down function, the status moves to Power Save after the given Cooling down operation.

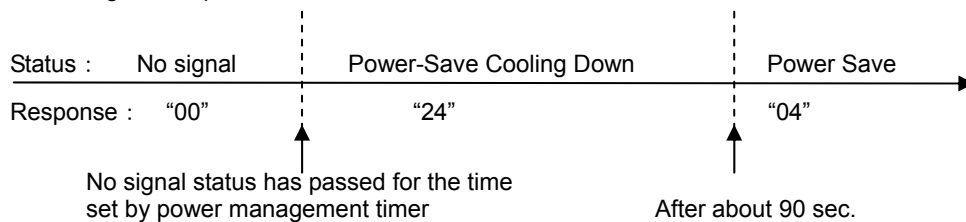

- **"04" [CR]**

Status: Power Save

This indicates it moves to Power-Save status by Power Management function as set in the Setting menu.

- **"21" [CR]**

Status: Cooling Down in process after OFF due to Lamp Failure

When the projector is turned off due to lamp failure, it automatically starts Cooling Down

LV-7585 Basic Serial Command Functional Specifications

operation. The projector returns "21" [CR]. "21" [CR] has been kept during Cooling Down operation.

- **"81" [CR]**

Status: Standby after Cooling Down due to Lamp Failure

The projector has recovered from Lamp Failure status. When the projector enters Standby status after Cooling Down operation invoked due to lamp failure, it returns "81". This indicates the status turns to Standby due to lamp failure. This status continues until the next operation is started; when Power On is executed, the projector clears the information of Lamp Failure and normal operation starts.

7.4 Input Mode Read Command

Command	"CR1" [CR]	
Detail	Get currently selected Input No.	
Response	Acceptable	"%1" [CR]
	%1	"1" = Input 1 is selected. "2" = Input 2 is selected. "3" = Input 3 is selected. "4" = Input 4 is selected.(only for Networking-capable models)
	Unacceptable	"?" [CR]

7.5 Lamp Time Read Command

Command	"CR3" [CR]	
Detail	Get total lamp running hours. *return lamp operating time multiplied by the given coefficient (not actual used time)	
Response	Acceptable	"%1" [CR]
	%1	Display Lamp running hours with 5 digit numbers. Example: "00410" [CR] ----- 410 hours
	Unacceptable	"?" [CR]

7.6 Setting Read Command

Command	"CR4" [CR]	
Detail	Get screen setting status such as Ceiling/Rear.	
Response	Acceptable	"%1" [CR]
	%1	"11" [CR] = Normal Screen Setting "10" [CR] = Picture is top/bottom reversed. (Status: Rear & Ceiling ON) "01" [CR] = Picture is left/right reversed. (Status: Rear ON) "00" [CR] = Picture is top/bottom and left/right reversed. (Status: Ceiling ON)
	Unacceptable	"?" [CR]

7.7 Temp Read Command

Command	"CR6" [CR]	
Detail	Get the information of temperature inside a projector. With several built-in temperature sensors, it can get all the temperatures at once.	
Response	Acceptable	"%1 _ %2 _ %3" [CR]
	%1 %2 %3	%1 = Temp. of sensor 1 %2 = Temp. of sensor 2 %3 = Temp. of sensor 3 Temperature data basic format is "_00.0". ("_" indicates a space) When the temperature goes under 0, it starts with "-" instead of a space like "-05.5" [CR]. When no temperature data returns due to hardware problems, it starts with "E" like"E00.0" [CR]. With several built-in temperature sensors, the projector returns the values in succession. "_ 31.5_ 35.2_ 33.4 " [CR] The first sensor's data is followed by one space and afterwards the second sensor's data.
	Unacceptable	"?" [CR]

7.8 Lamp Mode Read Command

Command	"CR7" [CR]	
Detail	Get lamp mode. In the projector with single lamp, get ON/OFF status of the lamp	
Response	Acceptable	"%1" [CR]
	%1	"00" [CR] = Lamp is ON. "01" [CR] = Lamp is OFF.
	Unacceptable	"?" [CR]